



OFFICIAL NOTICE & AGENDA
REGULAR MEETING

MEETING: Bicycle & Pedestrian Advisory Committee
DATE/TIME: Monday, March 23, 2026 at 5:00 PM
LOCATION: Wausau City Hall — Council Chambers
407 Grant Street, Wausau WI, 54403

MEMBERS:
Jonathan Smith (C) Chris Filtz
Tom Neal Ben Gerhards
Terry Kilian Veronica Hope
Susan Schmidt Brad Lenz
(Ex Officio)

1 Call to order by the presiding officer.

2 Public comment.

3 Consideration of the minutes of the preceding meeting(s).

Discussion and possible action approving the February 23, 2026, meeting minutes.

4 Discussion and possible action.

- a. Discussion and possible action approving 2026-2027 City sidewalk snow removal policy.
- b. Discussion and possible action approving City bike rack request form.
- c. Discussion and possible action approving May National Bike Month events and promotion.

5 Discussion.

- a. Discussion on potential opportunities to provide youth safety flags and/or lights.
- b. MPO Bike/Ped Subcommittee update
- c. City of Schofield Trail Concepts

6 Update on City Projects

- a. Bikeshare expansion
- b. RRFB installation 6th Avenue/Bridge Street and 1st Avenue/Callon Street
- c. River Edge Parkway

7 Items for future agendas.

8 Adjournment.

**Next meeting scheduled for .*

Jonathan Smith, Chair

**NOTICE POSTED AT CITY HALL (407 GRANT STREET) AND
TRANSMITTED TO THE OFFICIALLY DESIGNATED NEWSPAPER**

DATE: March 17, 2026
TIME: 11:30 a.m.
POSTED BY: Carrie Edmondson, AICP, Assistant City Planner

In accordance with the requirements of Title II of the Americans with Disabilities Act of 1990 (ADA), the City of Wausau will not discriminate against qualified individuals with disabilities on the basis of disability in its services, programs or activities. If you need assistance or reasonable accommodations in participating in this meeting or event due to a disability as defined under the ADA, please call the ADA Coordinator at (715) 261-6622 or ADAServices@wausauwi.gov to discuss your accessibility needs. We ask your request be provided a minimum of 72 hours before the scheduled event or meeting. If a request is made less than 72 hours before the event the City of Wausau will make a good faith effort to accommodate your request.

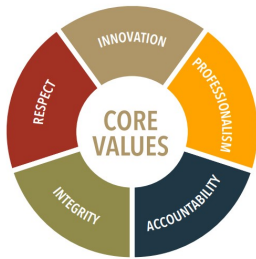

City of Wausau
(715) 261-6500 | clerk@wausauwi.gov
wausauwi.gov



MINUTES

February 23, 2026

Members Present: Jonathan Smith (Chair), Alder Tom Neal, Alder Terry Kilian, Chris Filtz, and Veronica Hope

Others Present: Makayla Galecki (Wausau MPO), Lt. Jillian Kurtzhals, Jim Tlusty, Dave Wood, and Carrie Edmondson

Location: Wausau City Hall, 407 Grant Street, Maple Room

In compliance with Chapter 19, Wisconsin Statutes, notice of this meeting was posted and transmitted to the Wausau Daily Herald in the proper manner.

1. Call to Order

Chair Smith called the meeting to order at 5:00 p.m.

2. Public Comment

Jim Tlusty spoke about the lack of snow removal on Grand Avenue near Kent Street. He saw someone in a wheelchair using Grand Avenue because the sidewalk was not accessible. Dave Wood also reported issues with sidewalk clearing in that area.

3. Consideration of the January 26, 2026, meeting minutes.

Motion/second by Neal/Kilian to approve. Passed unanimously. 5-0

4. Discussion and possible action

a. Wausau MPO Draft Model E-Bike Ordinance

Carrie noted that she had met with Director Polley, Parks Director and the Police Department and had noted their comments. Alder Kilian noted that enforcement is still problematic because often once reported it is too late. Lt. Kurtzhals noted that the CSO's are out along the River Edge Parkway and they assist with enforcement if someone is operating in an erratic or unsafe manner. Alder Neal said the presence of the CSO provides a deterrent and that we need to be aggressive with signage. Chair Smith did not support including one-wheels specifically. Chris Filtz noted he would like to include anything without pedals as not allowed on the trails. Alder Neal expressed the importance of including all devices in this code. Carrie clarified that this ordinance will be brought back as a draft and most likely move through Public Health and Safety Committee on to Common Council. Director Polley noted that the east side of the River Edge Parkway and the west side will be signed in spring. She is still considering whether an additional sign should be placed near the playground at Riverlife Park.

Motion/second by Neal/Filtz to incorporate comments and bring a draft forward. Passed unanimously, 5-0.

- b. Spring newsletter submittal – due 3/6/26
Jonathan will be preparing a newsletter submittal about his Mellow Streets map.

5. Discussion

- a. Sidewalk Snow Removal Process and Procedure
Carrie presented an overview prepared by Kurt DuBore on the process for reporting sidewalk snow removal complaints, issuing violation letters, and assessing fees for cleaning and administration. Chris Filtz noted that Westwood Avenue sidewalks have not been cleared and that people are walking along Bridge Street. Alders Kilian and Neal noted that the seven days after a Violation Letter is mailed is too long for the sidewalk to not be cleared and thought a more aggressive process is in order. Chris Filtz agreed due to the fact that this is a safety concern. There was group consensus that this process must be improved to facilitate safety and accessibility.
- b. MPO Bike/Ped Subcommittee Update
 - Bicycle Friendly Community application – Carrie is working with Wausau School District to complete the Education section.
 - Safe Streets and Roads for All (SS4A) grant update. The MPO did not receive the grant, but were given direction to make adjustments and resubmit.
 - Grand Avenue design. The City of Schofield has similar concerns about the Grant Avenue design
 - Wisconsin Healthy Communities Summit will be held April 23-24, 2026, at the Hilton Garden Inn.

6. Update on City projects.

- a. Bikeshare expansion – City staff has started the sponsorship campaign.
- b. RRFB installation 6th Avenue/Bridge Street and 1st Avenue/Callon Street
No update.
- c. River Edge Parkway – Northcentral Technical College has made a stencil for the on-street logo that will be painted along the on-street portion of the River Edge Parkway.

7. Items for future agendas.

- Sidewalk snow removal process and procedure
- RRFB update
- Bike flags – City of Wausau or outside sponsorship
- River Edge Parkway

8. Next meeting date.

The next regular meeting is scheduled for March 23, 2026.

9. Adjournment

Motion/second by Neal/Filtz to approve. Passed unanimously. 5-0



Planning, Community and Economic Development

Date: March 23, 2026

To: Bicycle and Pedestrian Advisory Committee

From: Carrie Edmondson, AICP, Assistant City Planner

RE: Sidewalk Snow Removal Process and Procedure

In February, the Bicycle and Pedestrian Advisory Committee (BPAC) had the opportunity to discuss the City's current sidewalk snow removal policy. Committee member concerns included:

- Sidewalk safety for residents
- Pedestrian accessibility
- Excessive delay by some property owners to remove snow from sidewalks
- Repeat offenders of excessive delay of sidewalk snow removal
- The code violation process being too lengthy

The current code violation works as follows:

1. Complaint submitted – email, phone call, website, Facebook, or word of mouth
2. Inspection – typically within 24 hours.
3. Letter – if properties are found to be found in violation – letter mailed giving seven days to come into compliance.
4. Second inspection – if still not in compliance, request sent to REVI.
5. REVI removes snow within two days.
6. Property owner charged REVI fee plus \$40.

After hearing the concerns of BPAC, staff is suggesting the following changes to policy and procedure for the 2026-2027 snow season:

If a property has had one confirmed code violation during the snow season and this is the second or greater time they are found to be in violation, REVI will be called after the first inspection. The Code Violation Letter would be amended to reflect the change in policy. The change will go into effect for the 2026-2027 snow season, and the change will be heavily publicized at the start of the season.





Planning, Community and Economic Development

Date: March 23, 2026

To: Bicycle and Pedestrian Advisory Committee

From: Carrie Edmondson, AICP Assistant City Planner

RE: City Bike Rack Request Policy

The City is continuing to work to formalize its Bike Rack Request policy. We have currently been using two styles made by students at Northcentral Technical College (NTC). Our current inventory includes six bike racks (two with Wausau name, four without). Attached is a draft bike rack request form. Some items to consider:

- Bike racks can only be installed in the public right-of-way.
- A concrete pad is required for solid and sustainable installation.
- Cost is approximately \$100 per rack. DPW can work installation at no charge into their workflow, with pacing depending upon their other responsibilities.
- The BPAC may want to establish guidelines so that individual requests could be approved by staff. Requests with unique attributes could still go through BPAC.



City of Wausau Bike Rack Request Form



The City of Wausau seeks to create an environment that is safe and conducive to biking! This includes being able to park a bike quickly and safely near your destination. See a need? Use this form to request a new bike rack near a property that you own or identify an existing rack that needs to be repaired or replaced.

Bike Rack Location Requirements:

- Must have at least 2 feet by 6 feet space available so that a bike can be locked to either side of the rack.
- Must not block the sidewalk path or any fire hydrants, emergency exits, utility access points, etc. when a bike is locked to the rack.
- Cannot be on private property.
- [See 23.06.06\(19\) Bicycle Parking Standards](#) for more information.

Business Name: _____

Street Address: _____

Email: _____

Phone: _____

Please describe the requested location:

Why is this a good location for a bike rack?

Do you anticipate additional projected bike rack needs/if so do you have additional space available?

City of Wausau Bike Rack Request Form



The City of Wausau seeks to create an environment that is safe and conducive to biking! This includes being able to park a bike quickly and safely near your destination. See a need? Use this form to request a new bike rack near a property that you own or identify an existing rack that needs to be repaired or replaced.

Bike Rack Location Requirements:

- Must have at least 2 feet by 6 feet space available so that a bike can be locked to either side of the rack.
- Must not block the sidewalk path or any fire hydrants, emergency exits, utility access points, etc. when a bike is locked to the rack.
- Cannot be on private property.
- [See 23.06.06\(19\) Bicycle Parking Standards](#) for more information.

Business Name: _____

Street Address: _____

Email: _____

Phone: _____

Please describe the requested location:

Why is this a good location for a bike rack?

Do you anticipate additional projected bike rack needs/if so do you have additional space available?

Bike Rack Fabrication Overview – NTC Welding

Needs and Locations

New Bike Rack request form

Existing Rack Design

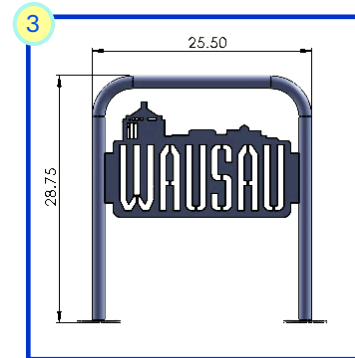
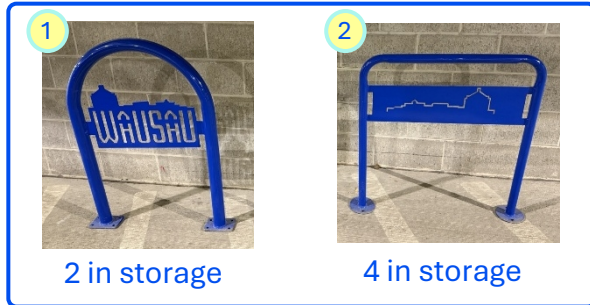

Possible Design for additional racks

Cost - #3 Rack

Item	Estimated Cost
Steel	~ \$50
Paint (JTech)	~ \$30
Paint (Goetsch's Welding & Machine)	~ \$10

Fabrication at NTC

- **NTC Capability:** Rack #3 can be produced at NTC using existing welding and fabrication equipment.
- **Customization:** The center design element can be modified to reflect different themes, and the size of the rack can be modified as recommended.
- **Timeframe:** Classes run August through May, ideal timeframe is April/May.
- **Student Learning:** The project aligns with competencies in our fabrication courses - well suited for student work.
- **Student Impact:** Community projects provide students with pride of craftsmanship and the opportunity to see their work used in the community.

Possible Upgrades (if rack #3)

Stainless Steel Mount Pad - to reduce rust on concrete over time - ~ \$10 added
 Stainless for entire rack – to increase lifespan of entire rack - ~ \$200 material cost

To Consider:

- Other Designs



NTC students could fabricate other designs in partnership with area industry.

- Colors and textures – virtually unlimited, paint can vary rack price ~ \$10.

Previously Built
In Storage



4 in storage



2 in storage

Possible Design for New Racks

- Approximate Cost - \$60 - \$80
- Design Panel can be customized
- Size can be modified
- Fabricated by NTC Welding Students
- Ideal fabrication timeframe: April/May

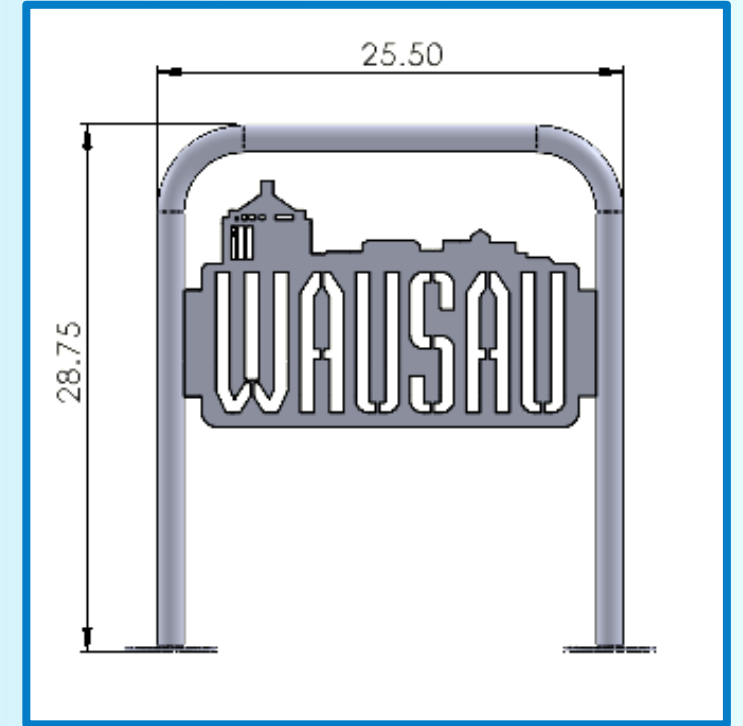
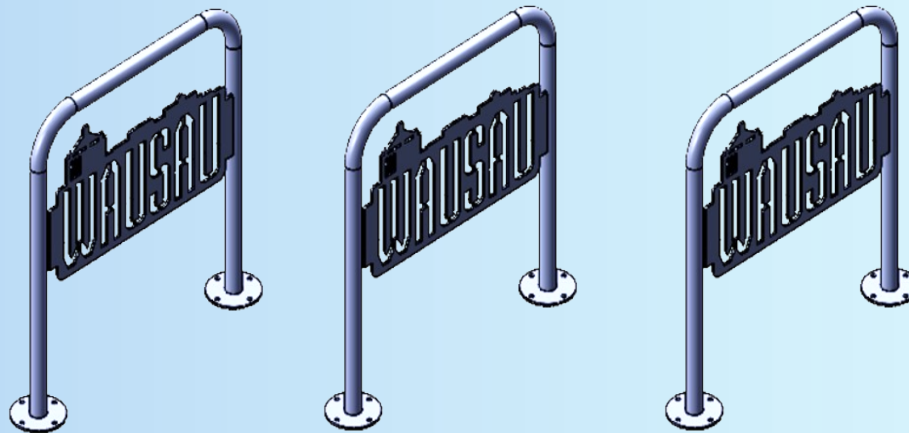

Community fabrication projects help students build real-world skills while contributing to the community.





Statement Regarding Bicycle Flags for Children

March 17, 2026

Wisconsin Bike Fed (Bike Fed) has concerns about advocating the use of flags for children's bikes.

Flags for children's bicycles are an unproven safety tool. The Bike Fed team knows of no studies on the effectiveness of flag use. They introduce physical challenges to novice riders, since flag poles can hamper movements and get caught on other objects, and provide excuses for laying blame on the most vulnerable of road users if the item is not attached to a bike at the time of a crash. When traveling in low light situations using lights on front and rear of the bike as well as reflectors on pedals and spokes, for a sideview increase in visibility, are more common visibility tools that may aide in a person driving seeing a person biking.

Children's developmental levels and ability to judge the speed of oncoming vehicles and situational awareness are not as developed as adults who are driving the cars. Riding on the sidewalk and stopping at curbs to wait to cross with someone older is generally the safest place for children under 10 to be riding. Bike Fed encourages all children and caregivers to follow rules of the road and safety tips when riding. Several digital and printed resources are available for free here <https://wisconsinbikefed.org/bike-education-resources/>

If increasing safety for the most vulnerable road users really is the goal, then we encourage reducing speed limits of motor vehicles. Speed reduction of motor vehicles is the number #1 proven means to keep all road-users safe regardless of mode or age. A copy of the U.S. Department of Education's, "PRIMER ON SAFE SYSTEM APPROACH FOR PEDESTRIANS AND BICYCLISTS" is attached.

This graphic visualizes the benefits of slowing speeds.

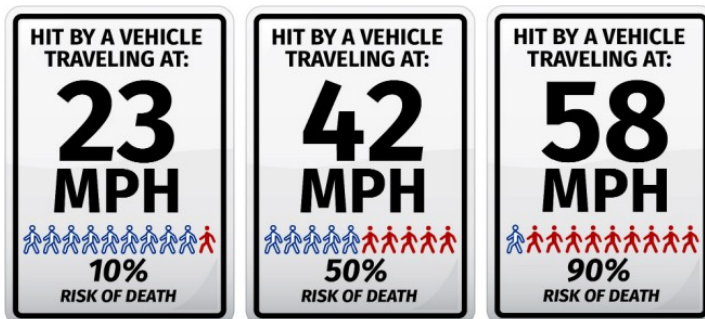

Studies have shown benefits from bicyclist education. If you would like members of the community to learn how to host a bike rodeo for kids, let us know. We have the funds to offer the class for free.

Christina Frain (she/her)

Statewide Adult Program Manager
christina@wisconsinbikefed.org

[League Cycling Instructor](#) # 7,713

Wear a properly-fitted helmet while riding your bike!

How to measure the head for helmet:

- Use a soft measuring tape to measure the circumference of the head about 1 inch above the eyebrows and above the ears around the largest part of the back of the head.
- Measure in centimeters to improve accuracy in helmet size.
- Measure over hair. Hair needs to be down or in very low ponytails. Hair should not be in high ponytails or other up styles. Get hair as flat on head as possible.
- Use the head measurement to select a helmet in the appropriate size. Doing this is more accurate than estimating by age.



Does your helmet fit properly? Take the Helmet Fit Test!

1



Eyes: Put the helmet on your head. Look up. You should see the bottom rim of the helmet.

There should only be one to two fingers width from the top of the brow to the bottom rim of the helmet.

2



Ears: Make sure the straps form a “V” under your ears when buckled. The straps should be a little tight but comfortable.

3



Mouth: Open your mouth as wide as you can. Is the helmet snug? If not, tighten the straps.

OR

Chin: There should be two fingers flat under your chin between you and the strap.

Learn more bike safety tips at: www.aspirus.org/bicycle-safety.

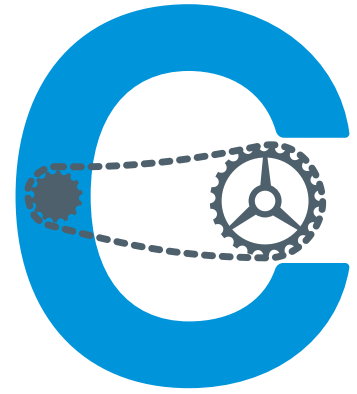
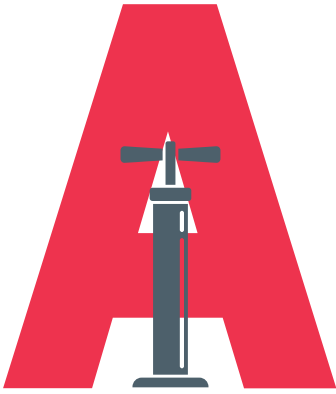

QUICK CHECK for Safety

A - Air

Check the air in your tires. They should be inflated toward the top end of the recommended PSI range listed on the side of the tire. If you don't have a pressure gauge, they should feel as firm as a fully inflated basketball. Also inspect your bike tires for damage or worn tread.

B - Brakes

Squeeze and release brakes to check for proper function before every ride. No working brakes - NO RIDE!

C- Chains

Check your bike's chain. The chain should move freely, be free of rust, and lightly oiled.

Quick Check

- Some bikes have **quick releases** on the wheels or the seat post. Check to make sure they are tight and closed properly. Follow your bike manufacturer's instructions.
- **Check** that your bike helmet fits properly. It should be snug (but not tight!) and level on your head.
- **Check** that everything is working properly by taking a very short ride. If everything is working properly and there's no rattles or squeaks indicating a problem, you're ready to roll!



This check should be done before every ride. If you're unsure whether a bike is safe or if something isn't working properly, please do not ride the bike. Have the bike inspected by an expert at a local bike shop.

Scan this QR Code to watch a video demonstrating the ABC Quick Check on kids' bikes. Video by Cascade Bicycle Club.



Led by:





Planning, Community and Economic Development

Date: March 23, 2026

To: Bicycle and Pedestrian Advisory Committee

From: Carrie Edmondson, AICP, Assistant City Planner

RE: City of Schofield Trail Concepts

The City of Schofield is evaluating the design and construction feasibility of a proposed trail connection from Moreland Avenue/Grand Avenue to E. Kent Street. The southern portion of the trail would be located within the City of Schofield, with the northern portion being located within the City of Wausau. The proposed trail would offer a bicycle and pedestrian alternative to the heavily traveled Grand Avenue corridor.

The City of Schofield is currently considering two conceptual options.

Concept 1: The northern City of Wausau portion would be located on private property, with the remaining portion located within the City of Schofield.

Concept 2: The northern City of Wausau portion would be located within the City of Wausau's Eau Claire River Conservancy with the remaining portion being located within the City of Schofield.

The City of Schofield is sharing the concepts for preliminary review and is continuing to evaluate the feasibility of both options. Staff is seeking feedback from the Bicycle and Pedestrian Advisory Committee on each concept and will relay the input to the City of Schofield.



EX 1
 LAYOUT: 2/18/2026 9:15 AM
 PLOT TIME: 2/18/2026 9:15 AM
 FILE NAME: P:\2025\2025.002 - Schofield - Misc Engineering - Eau Claire River Conservancy Trail CAD\Exhibits\Eau Claire River Conservancy Trail Exhibit.dwg
 Copyright © 2025, Becher-Hoppe Assoc. Inc.



BECHER HOPPE
 330 N. 4th STREET
 WAUSAU, WI 54403 • 715.845.8000
 becherhoppe.com

DRAWN BY: DAK
 CHECKED BY: AJW
 DATE: NOV 2025

PROJECT NO: 2025.002
 REV. DATES:

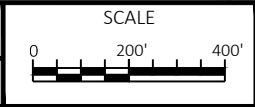

EAU CLAIRE RIVER CONSERVANCY TRAIL
 CITY OF SCHOFIELD

EXHIBIT

SHEET
 EX 1

EX 1
LAYOUT: 11/18/2025 11:54 AM
PLOT TIME: P:\2025\2025.002 - Schofield - Misc Engineering - Eau Claire River Conservancy Trail\CAD\Exhibits\Eau Claire River Conservancy Trail Exhibit.dwg
Copyright © 2025, Becher-Hoppe Assoc. Inc.



	330 N. 4th STREET WAUSAU, WI 54403 • 715.845.8000 becherhoppe.com
	DRAWN BY: DAK CHECKED BY: AJW DATE: NOV 2025

PROJECT NO: 2025.002 REV. DATES:

SCALE 0 150' 300'

EAU CLAIRE RIVER CONSERVANCY TRAIL CITY OF SCHOFIELD

EXHIBIT

SHEET EX 1
